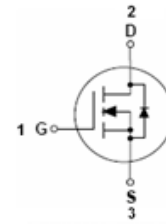


### Features

- Low power loss by high speed switching and low on-resistance
- Excellent thermal behavior
- Very low FOM for fast switching efficiency
- Product validation acc. JEDEC Standard
- HBM: JESD22-A114-B: 1B
- RoHS compliant with Halogen-free

HF

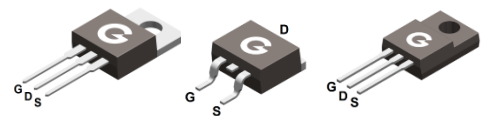


### Applications

- LED lighting
- Adapters
- Chargers
- Industrial power
- PFC stage

### Mechanical Data

- Case: TO-220AB, TO-263, ITO-220AB
- Molding Compound: UL Flammability Classification Rating 94V-0
- Terminals: Matte tin-plated leads; solderability-per MIL-STD-202, Method 208



TO-220AB TO-263 ITO-220AB

### Ordering Information

Part Number	Package	Shipping Quantity	Marking Code
SJM95R1K0	TO-220AB	50 pcs / Tube	SJM95R1K0
SJM95R1K0B	TO-263	50 pcs / Tube or 800 pcs / Tape & Reel	SJM95R1K0B
SJM95R1K0F	ITO-220AB	50 pcs / Tube	SJM95R1K0F

### Maximum Ratings (@ $T_C = 25^\circ\text{C}$ unless otherwise specified)

Parameter	Symbol	Value	Unit
Drain-to-Source Voltage	$V_{DSS}$	950	V
Gate-to-Source Voltage	$V_{GSS}$	$\pm 30$	V
Continuous Drain Current ( $T_C = 25^\circ\text{C}$ )	$I_D$	7	A
Continuous Drain Current ( $T_C = 100^\circ\text{C}$ )		4.4	
Pulsed Drain Current ( $t_p = 10\mu\text{s}$ , $T_C = 25^\circ\text{C}$ )	$I_{DM}$	28	A
Single Pulse Avalanche Energy <sup>2</sup>	$E_{AS}$	200	mJ
Power Dissipation (TO-220AB, $T_C = 25^\circ\text{C}$ )	$P_D$	96	W
Power Dissipation (TO-263, $T_C = 25^\circ\text{C}$ )		96	
Power Dissipation (ITO-220AB, $T_C = 25^\circ\text{C}$ )		31	
Operating Junction Temperature Range	$T_J$	-55 ~ +150	$^\circ\text{C}$
Storage Temperature Range	$T_{STG}$	-55 ~ +150	$^\circ\text{C}$

### Thermal Characteristics

Parameter	Symbol	Min.	Typ.	Max.	Unit
Thermal Resistance Junction-to-Case (TO-220AB, TO-263)	R <sub>θJC</sub>	-	0.9	1.3	°C/W
Thermal Resistance Junction-to-Case (ITO-220AB)		-	3.6	4	
Thermal Resistance Junction-to-Air (TO-220AB, TO-263)	R <sub>θJA</sub>	-	-	62	°C/W
Thermal Resistance Junction-to-Air (ITO-220AB)		-	-	75	

### Electrical Characteristics (@ T<sub>A</sub> = 25°C unless otherwise specified)

Symbol	Parameter	Test Condition	Min.	Typ.	Max.	Unit
<b>Static Characteristics</b>						
V <sub>DSS</sub>	Drain-Source Breakdown Voltage	V <sub>GS</sub> = 0V, I <sub>D</sub> = 250μA	950	-	-	V
I <sub>DSS</sub>	Zero Gate Voltage Drain Current	V <sub>DS</sub> = 950V, V <sub>GS</sub> = 0V	-	-	1	μA
I <sub>GSS</sub>	Gate-Body Leakage Current	V <sub>GS</sub> = ±30V, V <sub>DS</sub> = 0V	-	-	±100	nA
<b>On Characteristics</b>						
R <sub>DS(ON)</sub>	Drain-Source On-resistance *1	V <sub>GS</sub> = 10V, I <sub>D</sub> = 1.5A	-	0.83	1	Ω
V <sub>GS(th)</sub>	Gate Threshold Voltage	V <sub>DS</sub> = V <sub>GS</sub> , I <sub>D</sub> = 250μA	2.5	3.5	4.5	V
R <sub>G</sub>	Gate Resistance	V <sub>GS</sub> = 0V, f = 1MHz	-	10.9	-	Ω
<b>Dynamic Characteristics</b>						
C <sub>ISS</sub>	Input Capacitance	V <sub>GS</sub> = 0V V <sub>DS</sub> = 40V f = 250kHz	-	543	-	pF
C <sub>OSS</sub>	Output Capacitance		-	100	-	
C <sub>RSS</sub>	Reverse Transfer Capacitance		-	4	-	
<b>Switching Characteristics</b>						
t <sub>d(ON)</sub>	Turn-on Delay Time *3	V <sub>DD</sub> = 400V V <sub>GS</sub> = 10V I <sub>D</sub> = 3A R <sub>G</sub> = 10Ω	-	21	-	ns
t <sub>r</sub>	Turn-on Rise Time *3		-	21	-	
t <sub>d(OFF)</sub>	Turn-Off Delay Time *3		-	51	-	
t <sub>f</sub>	Turn-Off Fall Time *3		-	39	-	
Q <sub>G</sub>	Total Gate-Charge	V <sub>DD</sub> = 800V V <sub>GS</sub> = 10V I <sub>D</sub> = 3A	-	22.5	-	nC
Q <sub>GS</sub>	Gate to Source Charge		-	4.7	-	
Q <sub>GD</sub>	Gate to Drain (Miller) Charge		-	10.5	-	
<b>Source-Drain Diode Characteristics</b>						
V <sub>SD</sub>	Diode Forward Voltage *1	I <sub>SD</sub> = 3A, V <sub>GS</sub> = 0V	-	0.82	1.4	V
t <sub>rr</sub>	Reverse Recovery Time	I <sub>F</sub> = 3A, V <sub>GS</sub> = 0V	-	275	-	ns
Q <sub>rr</sub>	Reverse Recovery Charge	di/dt = 100A/μs	-	2.2	-	μC

Notes:

- The data tested by pulsed, pulse width ≤ 300μs, duty cycle ≤ 2%
- The E<sub>AS</sub> data shows Max. rating. The test condition is V<sub>DD</sub> = 100V, V<sub>GS</sub> = 10V, L = 50mH
- Guaranteed by design, not subject to production

### Ratings and Characteristics Curves (@ $T_A = 25^\circ\text{C}$ unless otherwise specified)

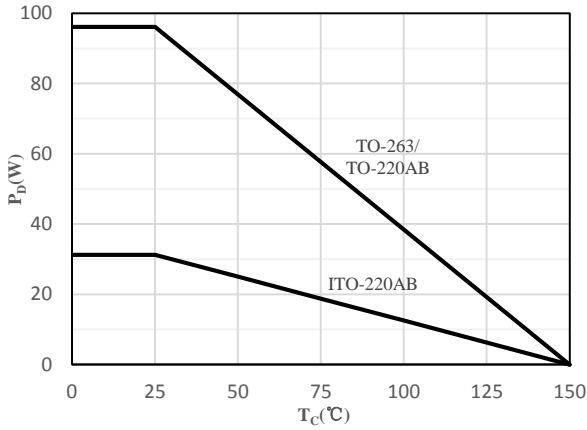


Fig 1 Power Dissipation

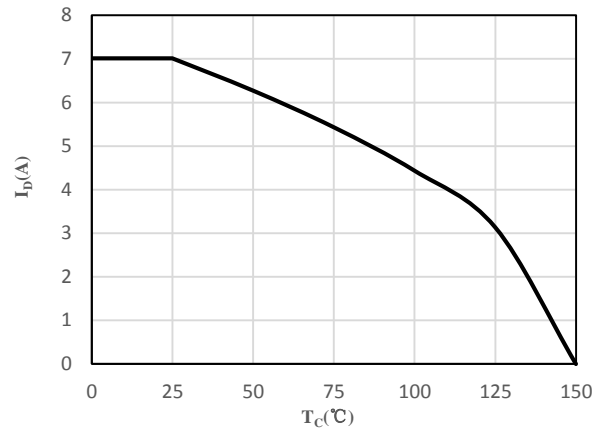


Fig 2 Drain Current

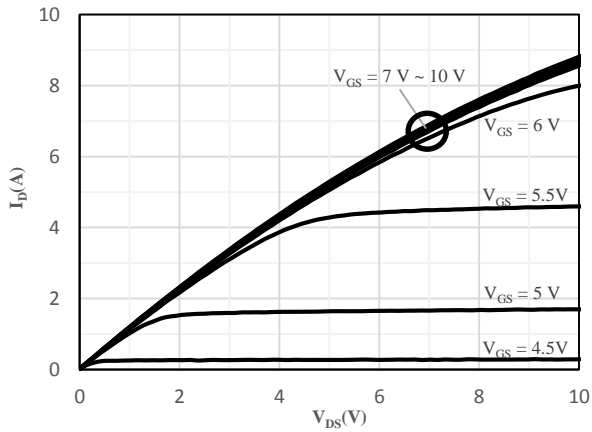


Fig 3 Typical Output Characteristics

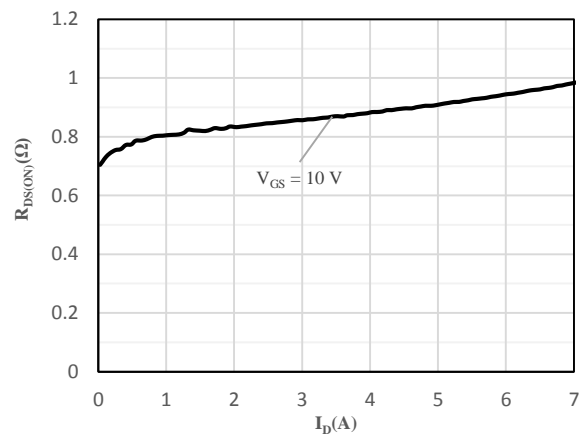


Fig 4 On-Resistance vs. Drain Current and Gate Voltage

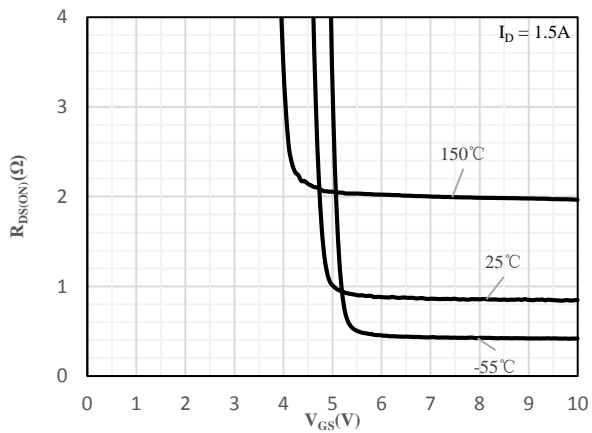


Fig 5 On-Resistance vs. Gate-Source Voltage

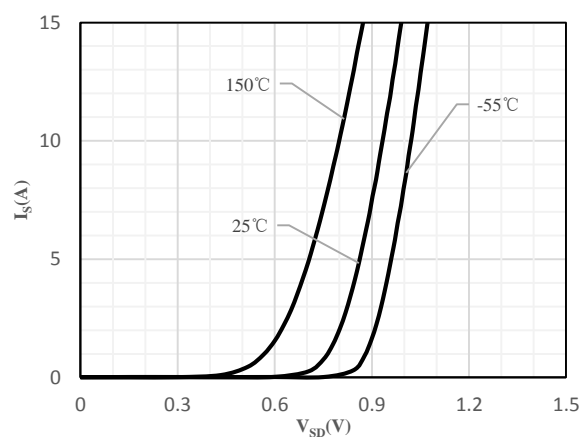


Fig 6 Body-Diode Characteristics

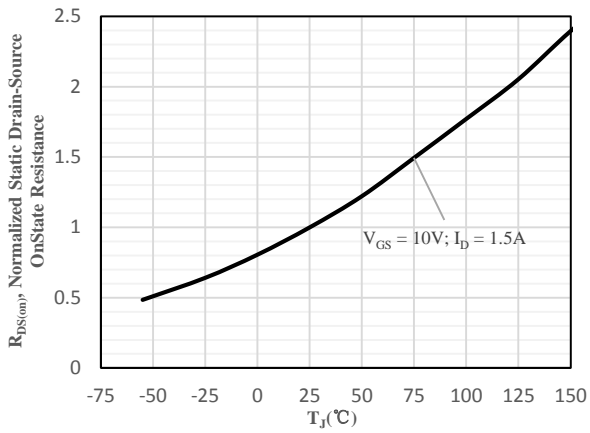


Fig 7 Normalized On-Resistance vs. Junction Temperature

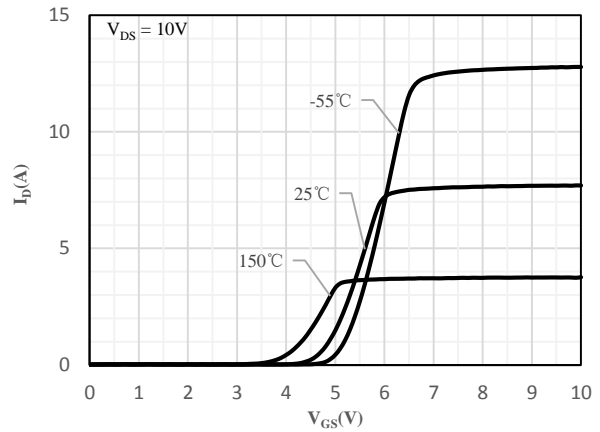


Fig 8 Transfer Characteristics

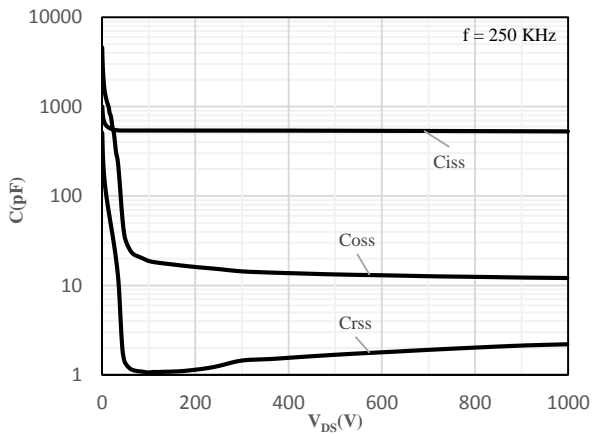


Fig 9 Capacitance Characteristics

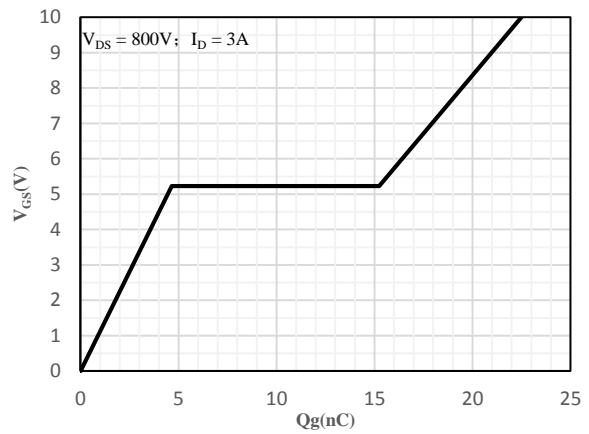


Fig 10 Gate-Charge Characteristics

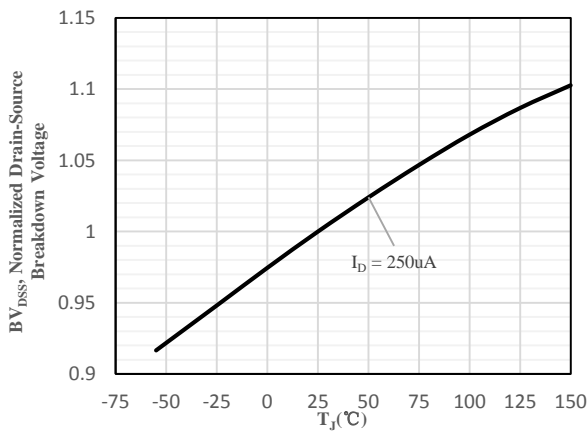


Fig 11 Normalized Breakdown Voltage vs. Junction Temperature

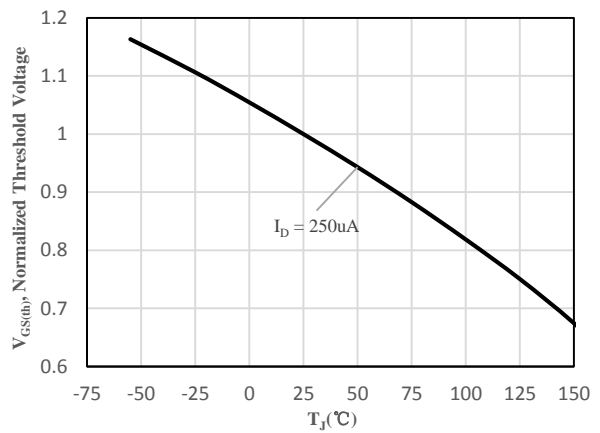
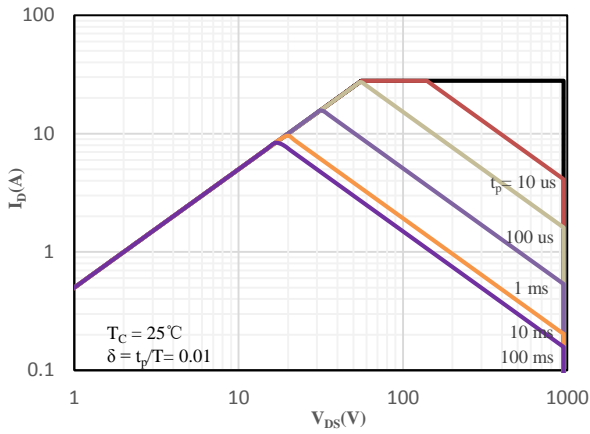
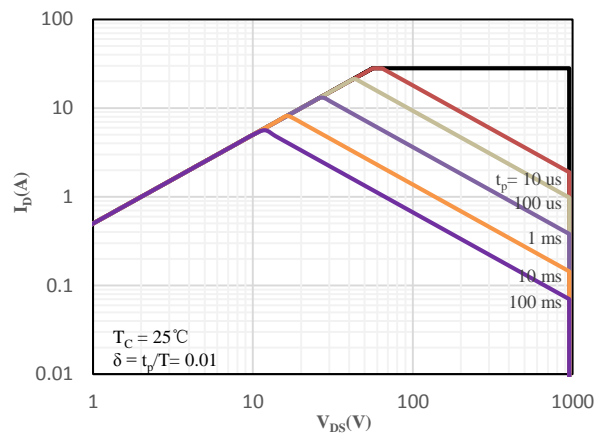


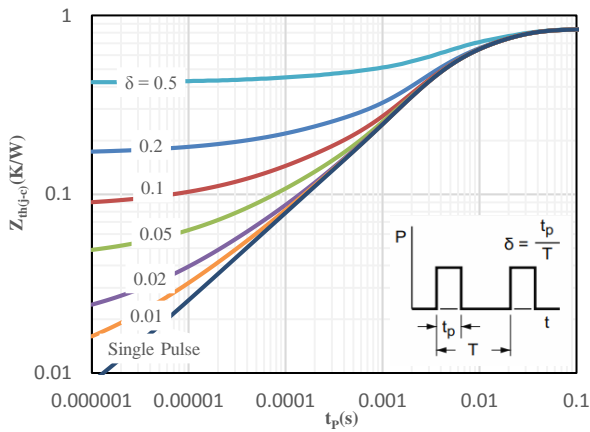
Fig 12 Normalized  $V_{GS(th)}$  vs. Junction Temperature



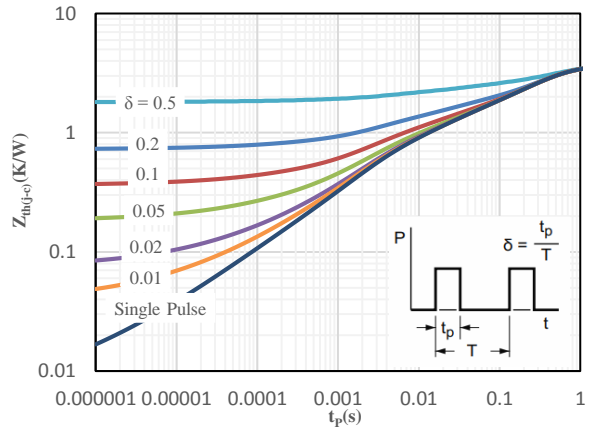
**Fig 13 Safe Operating Area (TO-220AB / TO-263)**



**Fig 14 Safe Operating Area (ITO-220AB)**

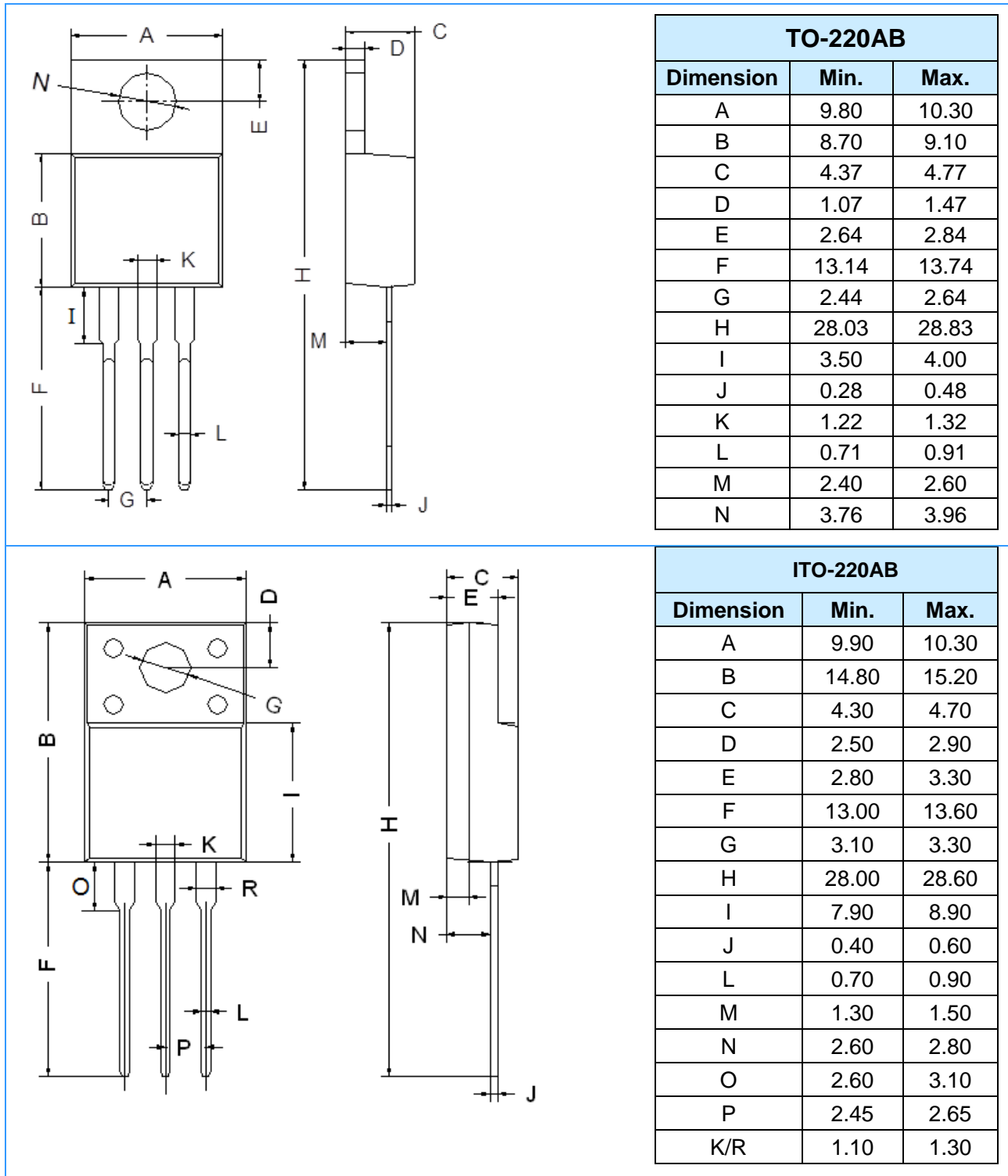


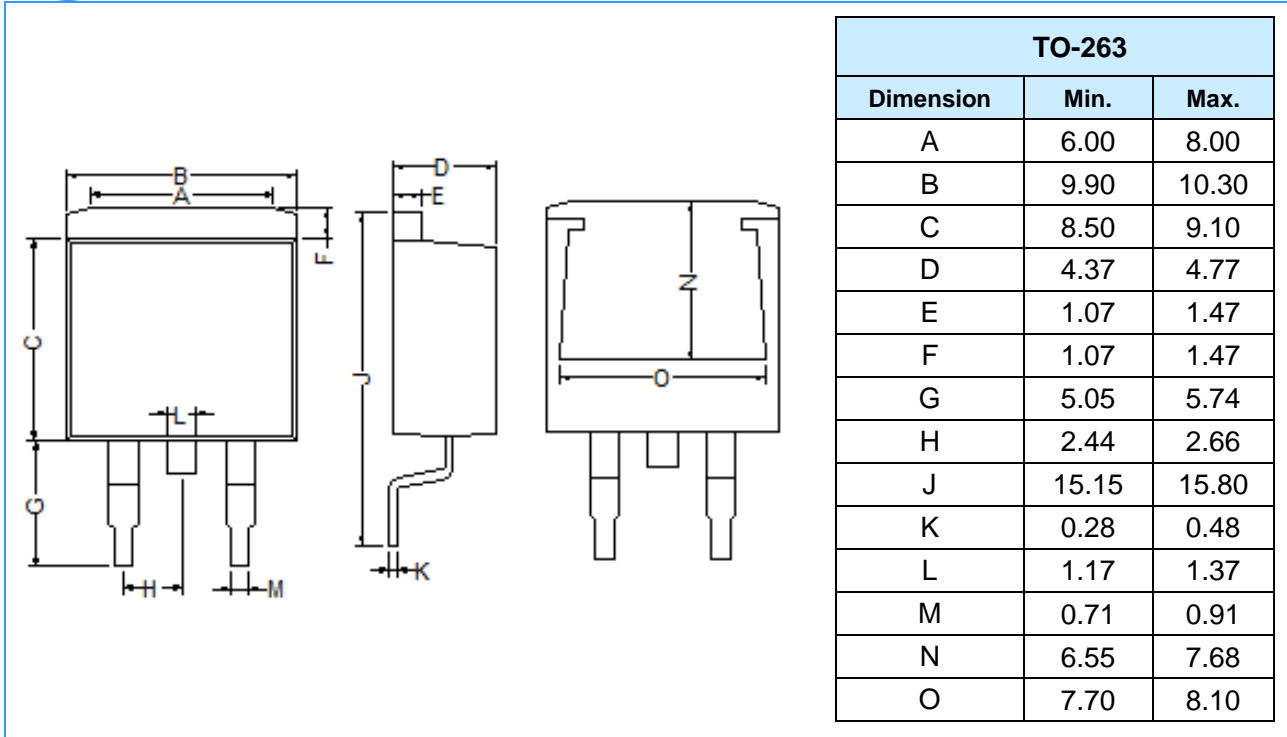
**Fig 15 Maximum transient thermal impedance (TO-220AB / TO-263)**



**Fig 16 Maximum transient thermal impedance (ITO-220AB)**

### Package Outline Dimensions (Unit: mm)





**Mounting Pad Layout** (Unit: mm)

